



ECLIPSE P400/P400s

PHANTEKS
DESIGNED IN THE NETHERLANDS

ECLIPSE SERIES

INTRODUCTION

Congratulations on your purchase of the Phanteks Eclipse Series Case and welcome to the User's Guide. Phanteks believes that meaningful designs are created through the fusion of form and function.

CAUTION

Please take a moment to carefully go through the installation guide. Phanteks will not take responsibility for any damages incurred due to incorrect installation and incorrect usage of this product. Thank you.

Phanteks continues its user friendly design chassis with the new Eclipse Series P400. Without much effort, the P400 allows users to create a clean and beautiful system. Ambient RGB illumination adds character while the solid metal exterior gives the case a simple elegant design. The P400 is suitable for beginners and experienced system builders with all the extra features.

The P400S comes with sound damping panels and a 3-speed fan controller to enhance acoustical performance.

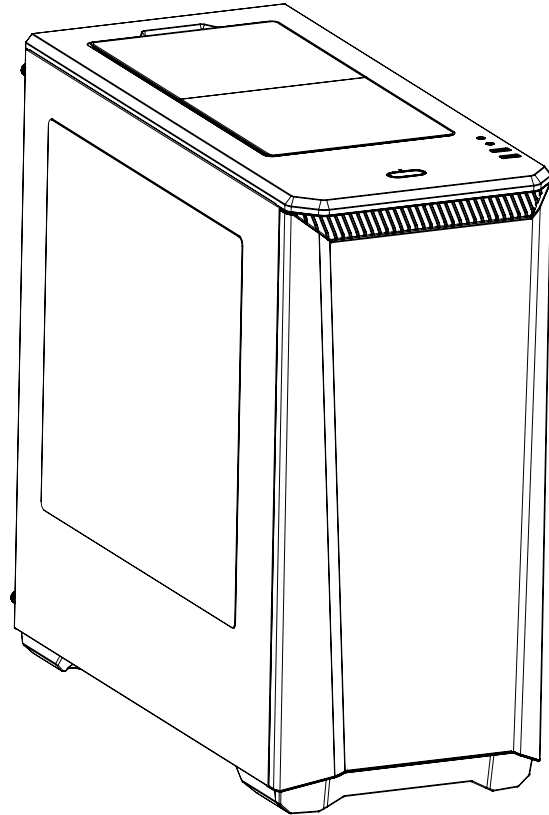

TABLE OF CONTENTS

1. SPECIFICATIONS	5
2. EXPLODED VIEW	6
3. ACCESSORIES	8
4. I/O PORTS	9
5. CONNECTIONS	10
6. PANEL REMOVAL	11
7. MOTHERBOARD INSTALLATION	13
8. POWER SUPPLY INSTALLATION	14
9. FILTERS REMOVAL	15
10. FANS COMPATIBILITY	16
11. HARD DRIVE INSTALLATION	17
12. HARD DRIVE CAGE	18
13. DROP-N-LOCK SSD BRACKET	19
14. WATERCOOLING INSTALLATION	20
15. OPTIONAL UPGRADES	22
16. SUPPORT AND SERVICES	24

1. SPECIFICATIONS

CASE SPECIFICATIONS

Dimension	210 mm x 465 mm x 470 mm (W x H x D) 8.3 in x 18.3 in x 18.5 in
Form Factor	Mid Tower
Material(s)	Steel chassis, steel exterior, ABS
Motherboard support	ATX, Micro ATX, Mini ITX E-ATX *(up to 272mm wide, unable to use rubber grommets)
Front I/O	2x USB 3.0, Mic, Headphone, Reset, LED Color Control, *3-Speed Fan controller (* Eclipse P400S models only)
Side window	Yes, Eclipse P400 (PH-EC416P) Yes, Eclipse P400S (PH-EC416PSW) No, Eclipse P400S closed panel (PH-EC416PSC)

EXPANSION & DRIVE BAYS

Expansion slots	7
Internal 3.5"	6 (2x included)
Internal 2.5" (dedicated)	2 (2x included)

COOLING (FANS)

	120 mm	140 mm
Front	3x (1x included)	2x
Top	2x	2x
Rear	1x (1x included)	-

LIQUID COOLING

	120 mm (Radiator)	140 mm (Radiator)
Front	Up to 360*	Up to 280
Top	-	-
Rear	120	-

*360 radiator requires the removal of the midplate cover

CLEARANCE

Graphic card	395 mm (15.2 in) 280 mm (11.0 in) <i>Optional HDD brackets installed</i>
CPU cooler	160 mm (6.3 in)
Cable Management	25 mm (1.0 in)
PSU (including cable)	270 mm (10.6 in)
Warranty	5 Years*

2. EXPLODED VIEW

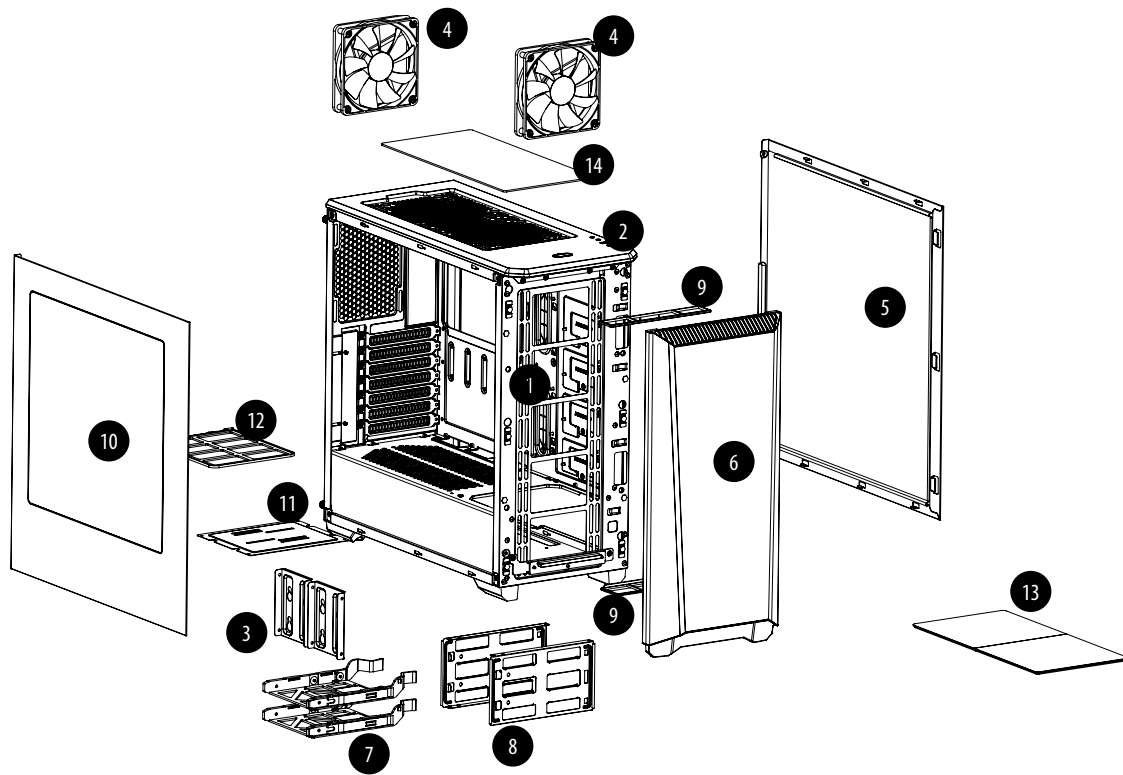

1. Chassis
2. Top Panel
3. SSD Brackets
4. Fans
5. Right Side Panel
6. Front Panel
7. HDD Tray
8. Hard Drive Cage
9. Front Dust Filter
10. Window Left Side Panel
11. Mid-plate Bracket
12. Rear Dust Filters
13. Top Covers (P400S models only)
14. Top Dust Filter

1. Châssis
2. Filtres de poussière inférieurs
3. Support SSD
4. Fans
5. Panneau latéral droit
6. Panneau frontal
7. Bacs HDD
8. Enclos du disque dur
9. Couverture de grille du panneau frontal
10. Panneau latéral gauche
11. Plaque centrale multifonctions
12. Panneau supérieur
13. Couvertures de ventilation supérieurs
14. Filtre à poussière supérieur

1. Telaio
2. Filtri antipolvere inferiori
3. Staffa SSD
4. Fans
5. Pannello laterale destro
6. Pannello frontale
7. Vassoi per disco rigido
8. Cage disco rigido
9. Copertura di rete frontale
10. Pannello laterale sinistro
11. Piastra centrale multifunzione
12. Pannello superiore
13. Pannelli superiori per la ventilazione
14. Filtro antipolvere superiore









1. Chassi
2. Painei Superior
3. Suporte do SSD
4. Fans
5. Painei Lateral Direito
6. Painei frontal
7. Tabuleiros de HDD
8. Berço do Disco Rígido
9. Tampa de malha frontal
10. Painei Lateral Esquerdo
11. Placa média multifuncional
12. Filtros de Pó Inferiores
13. Tampas de Ventilação Superior
14. Filtro de pós superior

1. Chasis
2. Panel superior
3. SSD-Halterung
4. Fans
5. Panel lateral derecho
6. Panel frontal
7. Bandejas de unidad de disco duro
8. Compartimento de disco duro
9. Cubierta de malla frontal
10. Panel lateral izquierdo
11. Placa central multifuncional
12. Filtros de polvo inferiores
13. Tapas de ventilación superiores
14. Filtro de polvo superior

1. Gehäuse
2. Untere Staubfilter
3. Suporte do SSD
4. Fans
5. Rechte Seitenblende
6. Frontblende
7. Festplatteneinsätze
8. Festplattenkäfig
9. Vordere Gitterabdeckung
10. Linke Seitenblende
11. Multifunktionale Platte in der Mitte
12. Untere Staubfilter
13. Obere Belüftungsabdeckungen
14. Oberer Staubfilter

1. Behuizing
2. Toppaneel
3. SSD beugel
4. Fans
5. Rechter zijpaneel
6. Voorpaneel
7. Harde schijf houder
8. Harde schijf kooi
9. Voorzijde stof filters
10. Linker zijpaneel
11. Multifunctional mid-plate
12. Bodem stof filter
13. Bovenzijde ventilatie deksels
14. Stof filter boven

3. ACCESSORIES

ITEM	DESCRIPTION	USE	QTY
	Screw M3 x 5mm	Motherboard/SSD	26
	Stand Off Screws	Motherboard	1
	Thumb Screws 9*15mm	HDD Bracket, Side Panel	2
	Thumb Screws 9*20mm	HDD tray	2
	Screw 5 x 10KT	Fan installation (top/rear)	12
	Screw 6-32 x 31 mm	Fan installation (front)	12
	Screw M4 x 8mm	Reservoir	8
	Screw 6-32 x 6mm	PSU	5

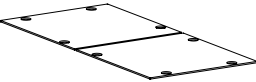
Top Dust Filters (P400S only)	
	Filtre à poussière supérieur Filtro antipolvere superiore Filtro de pós superior Filtro de polvo superior Oberer Staubfilter Stof filter boven

ITEM	DESCRIPTION	USE	QTY
	150mm	Zip Tie	6

4. I/O PORTS

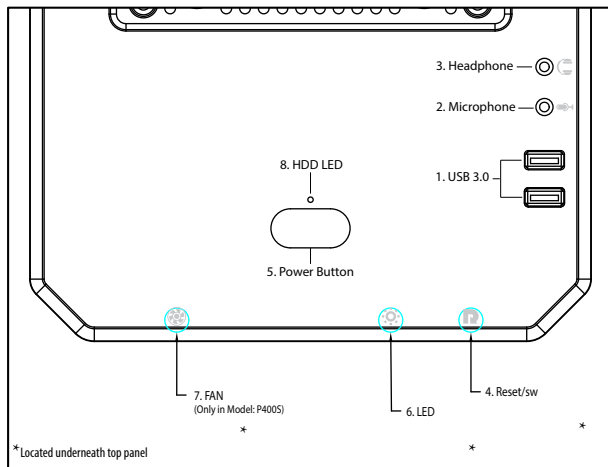

1. USB 3.0
2. Microphone
3. Headphone
4. Reset
5. Power Button
6. LED
7. FAN (P400S only)
8. HDD LED

1. USB 3.0
2. Microphone
3. Casque
4. Réinitialisation de l'alimentation
5. Bouton d'alimentation
6. LED
7. FAN (P400S only)
8. HDD LED

1. USB 3.0
2. Micrófono
3. Cascos
4. Resetear
5. Botón de alimentación
6. LED
7. FAN (P400S only)
8. HDD LED

1. USB 3.0
2. Microfone
3. Fone de ouvido
4. Redefinição de Energia
5. Botão de Alimentação
6. LED
7. FAN (P400S only)
8. HDD LED

1. USB 3.0
2. Microfono
3. Cuffie
4. Ripristino alimentazione
5. Tasto d'alimentazione
6. LED
7. FAN (P400S only)
8. HDD LED

1. USB 3.0
2. Mikrofon
3. Kopfhörer
4. Reset
5. Ein-/Austaste
6. LED
7. FAN (P400S only)
8. HDD LED

1. USB 3.0
2. Microfoon
3. Hoofdtelefoon
4. Power Reset
5. Power knop
7. FAN (P400S only)
8. HDD LED

5. CONNECTIONS

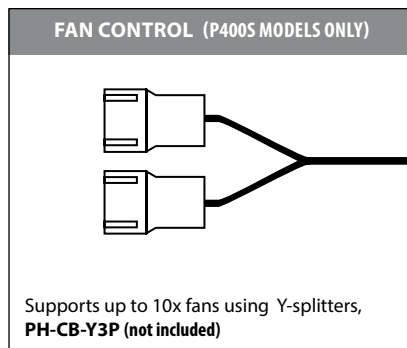
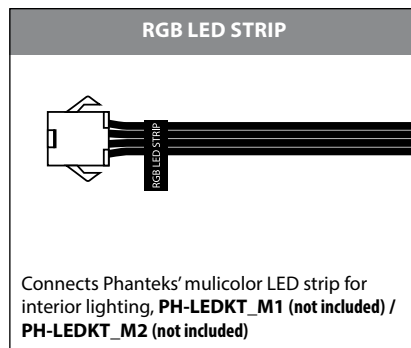
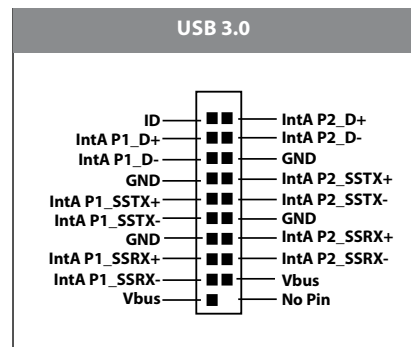
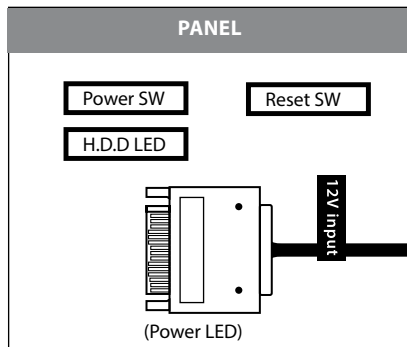
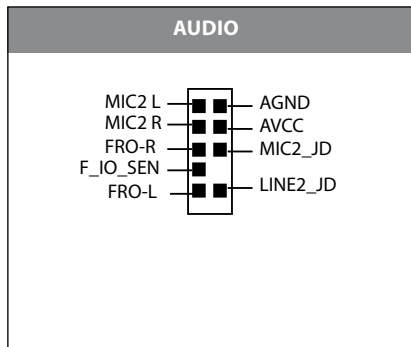

6. PANEL REMOVAL

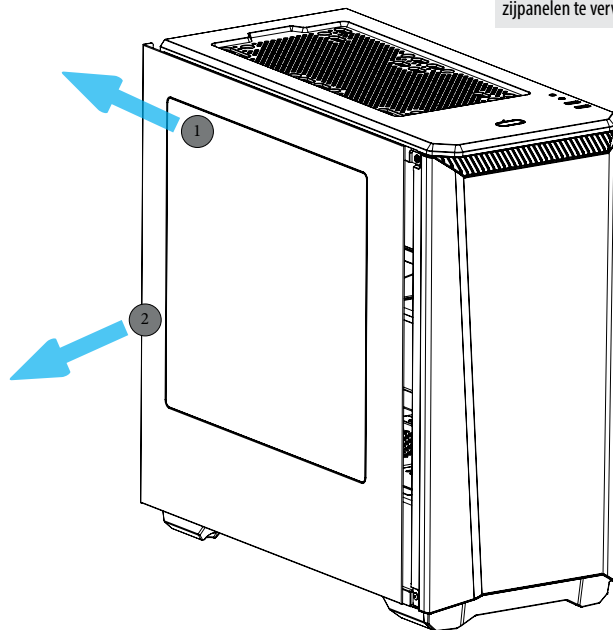
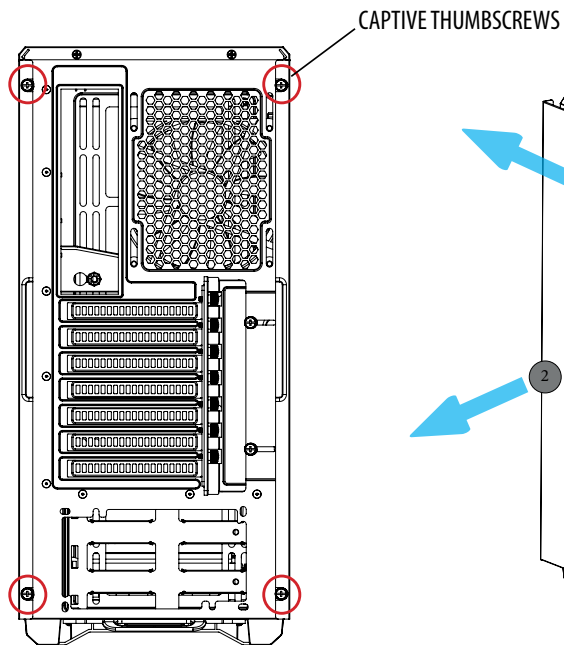

Unscrew the captive screws to remove the side panel

Dévissez les vis imperdables pour retirer le panneau latéral.

Lösen Sie zum Abnehmen der Seitenblende unverlierbaren Schrauben

Svitare le viti imperdibili per rimuovere il pannello laterale

Solte os parafusos cativos para remover o painel lateral.

Desatornille los tornillos cautivos para quitar el panel lateral.

Schroef 4 duimschroeven los (schroeven blijven op het paneel zitten) om de zijpanelen te verwijderen.

6. PANEL REMOVAL

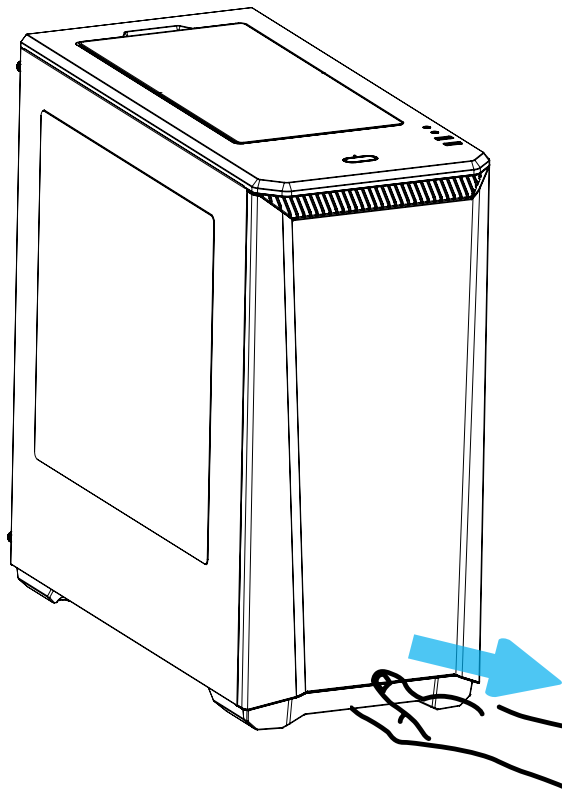

For the front panel, place your hands on the area shown and pull outward.

Pour le panneau avant, placez vos mains sur la zone affichée, et tirez vers l'extérieur.

Positionieren Sie auch bei der Frontblende Ihre Hände an der angezeigten Stelle und ziehen Sie sie dann nach außen.

Per il pannello anteriore, posizionare le mani sull'area mostrata e tirare verso l'esterno.

Para o painel frontal, coloque as mãos na área ilustrada e puxe para fora.

Para sacar el panel frontal, coloque las manos en el área indicada y tire hacia afuera.

Voor het verwijderen van het voorpaneel, trek het paneel naar u toe zoals aangegeven op de tekening.

7. MOTHERBOARD INSTALLATION

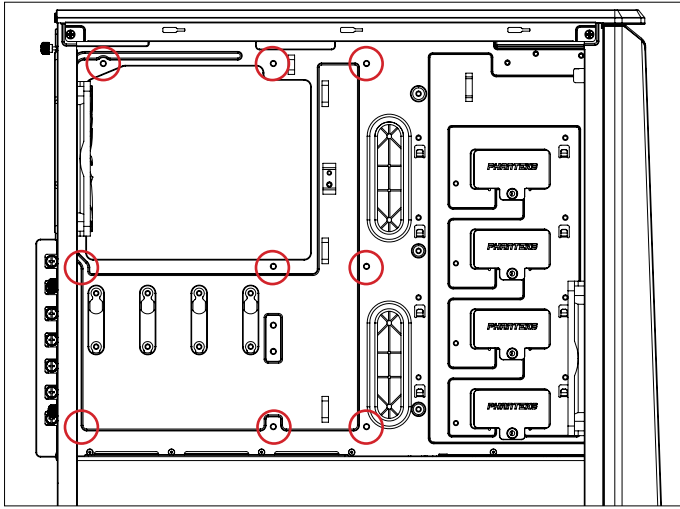

Standoff screws are pre-installed.

Les vis du support sont préinstallées.

Abstandhalter-schrauben sind vorinstalliert.

Le viti dei distanziatori sono installate precedentemente.

Os parafusos separadores estão pré-instalados.

Los tornillos separadores vienen preinstalados.

Afstandschroeven zijn vooraf geïnstalleerd.

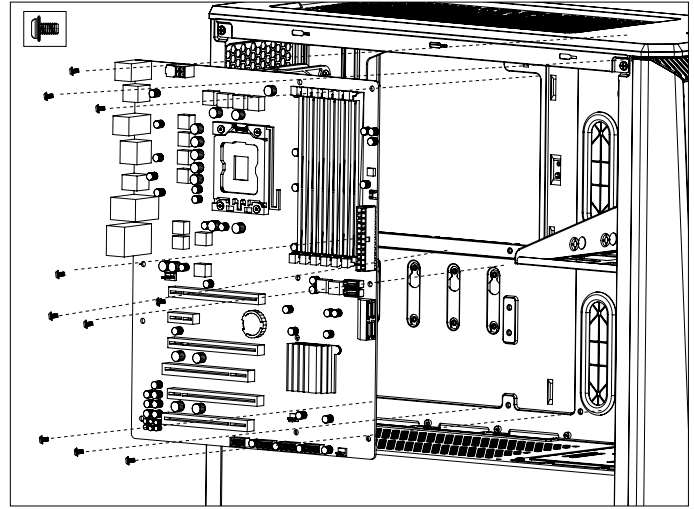

Install the motherboard with the provided M3 screws.

Installez la carte mère avec les vis M3 fournies.

Installieren Sie das Motherboard mit den mitgelieferten M3-Schrauben.

installare la scheda madre con le viti M3 fornite in dotazione. Instale a placa mãe com os parafusos M3 fornecidos.

instale la placa base con los tornillos M3 que se suministran.

Installeer het moederbord met de meegeleverde M3-schroeven.

8. POWER SUPPLY INSTALLATION

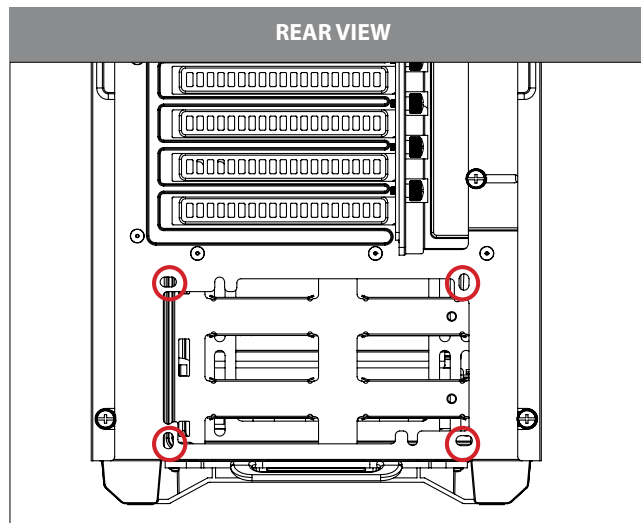
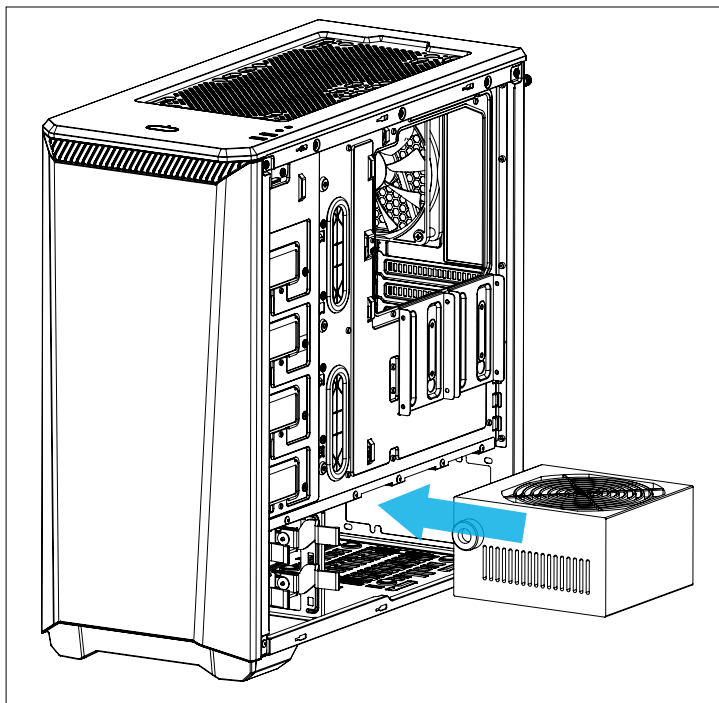

Use the provided screws to secure the PSU in place.

Utilisez les vis fournies pour fixer le bloc d'alimentation en place.

Befestigen Sie das Netzteil mit den mitgelieferten Schrauben.

Utilizzare le viti fornite per fissare la PSU in sito.

Use os parafusos para fixar a Unidade de Proteção e de Comutação.

Utilice los tornillos suministrados para fijar la fuente de alimentación en su posición.

Gebruik de meegeleverde schroeven om de voeding vast te zetten.

9. FILTERS REMOVAL

To remove the bottom and front filter pull out. Mesh cover on top panel can also be cleaned.

Pour retirer les filtres en bas et à l'avant, tirez dessus. La grille du panneau avant peut aussi être nettoyée.

Ziehen Sie den unteren und vorderen Filter heraus. Die Gitterabdeckung an der oberen Blende kann ebenfalls gereinigt werden.

Tirare verso l'esterno per rimuovere il filtro inferiore e anteriore. È possibile lavare anche la copertura a rete sul pannello superiore.

Puxe para remover o filtro inferior e frontal. A tampa de rede do painel superior também pode ser limpa.

Para sacar el filtro inferior/frontal tire de él hacia afuera. La cubierta de malla del panel superior también se puede limpiar.

Voor het verwijderen van de stofilter bodem en voor, trek deze uit via de handvat. Mesh filter op het bovenpaneel kunnen ook schoongemaakt worden.

To clean the dust filters, run slow moving water through the filters. Dry filters before reinstalling.

Pour nettoyer les filtres à poussière, faites couler de l'eau sur les filtres. Séchez les filtres avant de réinstaller.

Reinigen Sie die Staubfilter, indem Sie sie unter langsam fließendem Wasser abspülen. Filter vor Wiedereinbau trocknen.

Per pulire i filtri antipolvere, far correre lentamente l'acqua attraverso i filtri. Asciugare i filtri prima di installarli di nuovo.

Para limpiar os filtros de poeiras, passe água em movimento lento através dos filtros. Seque os filtros antes de reinstalar.

Para limpiar los filtros de polvo, deje que caiga agua corriente lentamente sobre los filtros. Seque los filtros antes de volverlos a colocar.

Laat langzaam stromend water door de filter lopen voor het reinigen van de filters. Droog de filters voordat u het weer bevestigd.

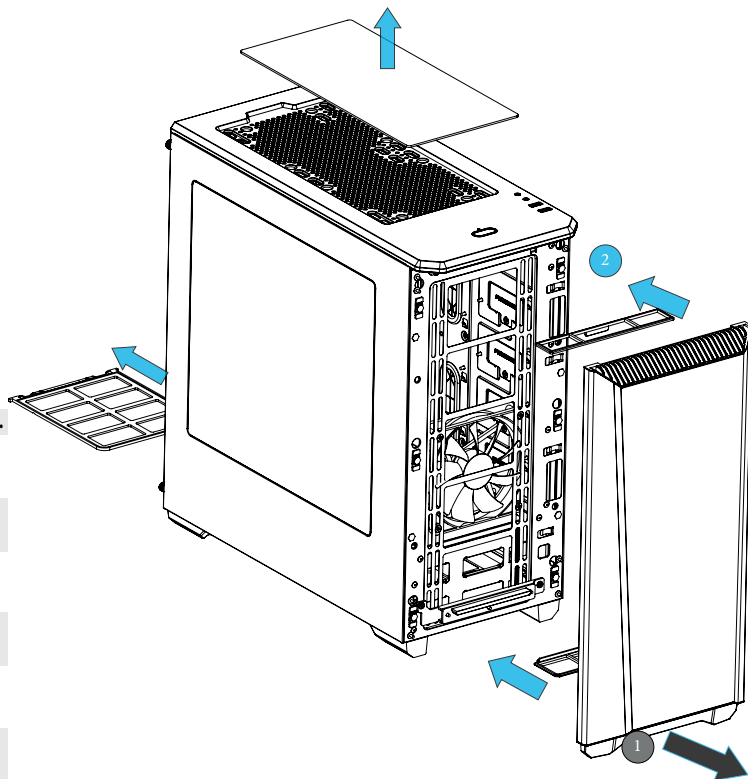

10. FAN COMPATIBILITY

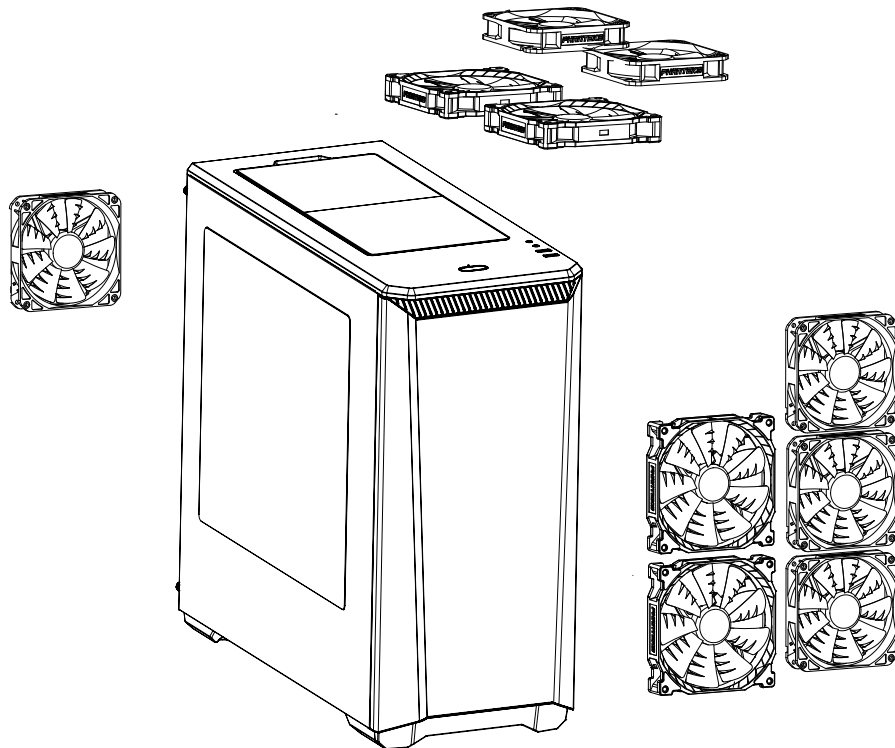

FAN COMPATIBILITY TABLE

	140mm	120mm
Top	2	2
Front	2	3
Rear	-	1

11. HARD DRIVE INSTALLATION

3.5" INSTALLATION

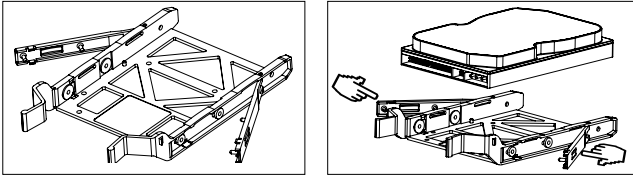

Place hard drive into tray and push in the arms to lock.

Placez le disque dur dans le logement et poussez les bras pour le verrouiller.

Bringen Sie die Festplatten im Fach an und drücken die Arme zum Verriegeln hinein.

Collocare disco rigido nel cassetto e spingere i bracci verso l'interno per bloccare.

Coloque o disco rígido na bandeja e empurre os braços para travar.

Coloque el disco duro en la bandeja y pulse sobre los brazos para que quede sujeto.

Plaats de harde schijf in de lade en duw de armen in voor vergrendeling.

2.5" INSTALLATION

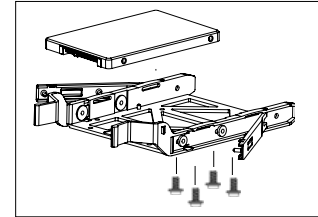

Align the SSD onto the mounting holes and screw in.

Aligner le SSD avec les trous de montage et vissez.

Richten Sie die SSD an den Montagelöchern aus und befestigen die Schrauben.

Allineare l'unità ssd su i fori di installazione e fissare le viti.

Alineie o SSD nos orifícios de fixação e parafuse.

Alinee la unidad de estado sólido con los agujeros de montaje y atornillela.

Lijn de SSD uit op de bevestigingsgaten en schroef de schroeven in.

12. HARD DRIVE CAGE

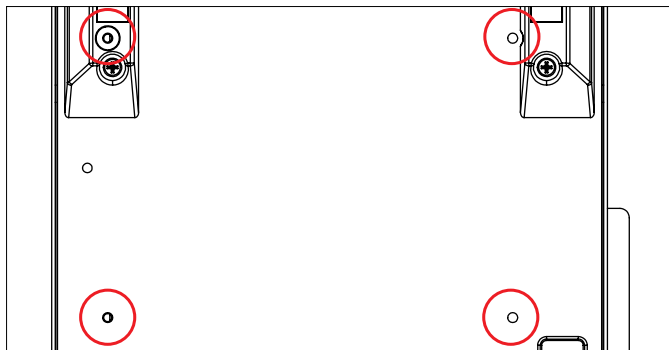
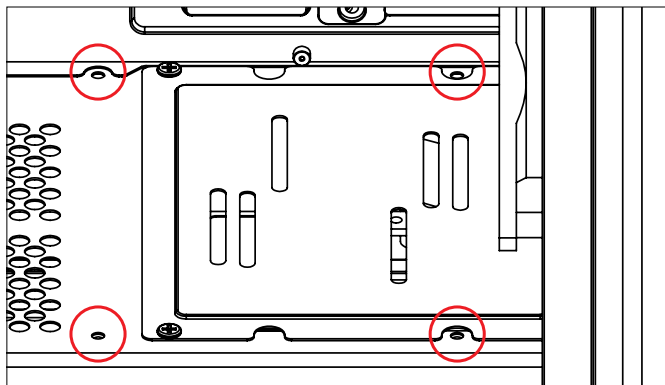

Bottom view of case

HDD BRACKET REMOVAL

To remove, unscrew the 4x screws on the midplate and the 4x screws on the bottom of the case.

Para remover, solte os 4x parafusos na placa do meio e os 4x parafusos na parte inferior do gabinete.

Zur Abnahme lösen Sie die 4 Schrauben an der mittleren Platte und die 4 Schrauben an der Unterseite des Gehäuses.

Per la rimozione, svitare le 4 viti sulla piastra intermedia e le 4 viti sulla parte inferiore del case.

Para remover, solte os 4x parafusos na placa do meio e os 4x parafusos na parte inferior do gabinete.

Para realizar la extracción, desatornille los 4 tornillos situados en la placa central y los 4 tornillos situados en la parte inferior de la carcasa.

Om te verwijderen, verwijder 4x schroeven op de middenplaat en 4x schroeven op de bodemplaat van de behuizing.

13. DROP-N-LOCK SSD BRACKET

SSD INSTALLATION

Slide in the SSD and screw in from the side to lock in place.

Faites coulisser le disque SSD et vissez-le depuis le côté pour le verrouiller dans son emplacement.

Schieben Sie die SSD ein und fixieren Sie diese seitlich mit Schrauben.

Far scorre l'unità SSD e fissare le viti dal lato per bloccarla in posizione.

Deslize para dentro do SSD e parafuse do lado para travar no local.

Deslice la unidad de estado sólido hacia adentro y atornillela desde el lateral para bloquearla en su lugar.

Schuif de SSD in en monteer de schroeven via de zijkant om deze te vergrendelen.

DROP N LOCK

Align the bracket to the rubber and drop down to lock.

Alignez le coin du support avec le guide et baissez-le pour verrouiller.

Richten Sie die Ecke der Halterung an der Führung aus und lassen sie einrasten.

Allineare l'angolo della staffa alla guida e calarla per bloccare.

Alinhe o canto do suporte ao guia e empurre para baixo para travar.

Alinee la esquina del soporte con la guía y empuje hacia abajo para que quede sujeta.

Plaats de beugel langs de uittijning in druk richting de pijl om te bevestigen.

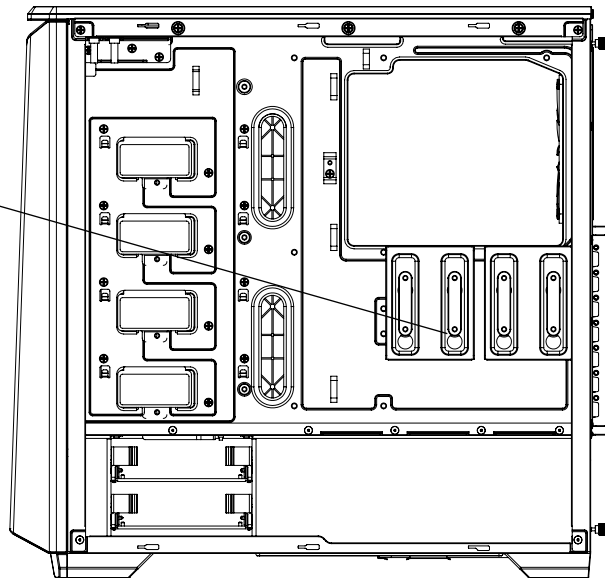
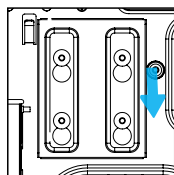
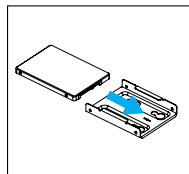

14. WATERCOOLING INSTALLATION

WATERCOOLING RADIATOR COMPATIBILITY

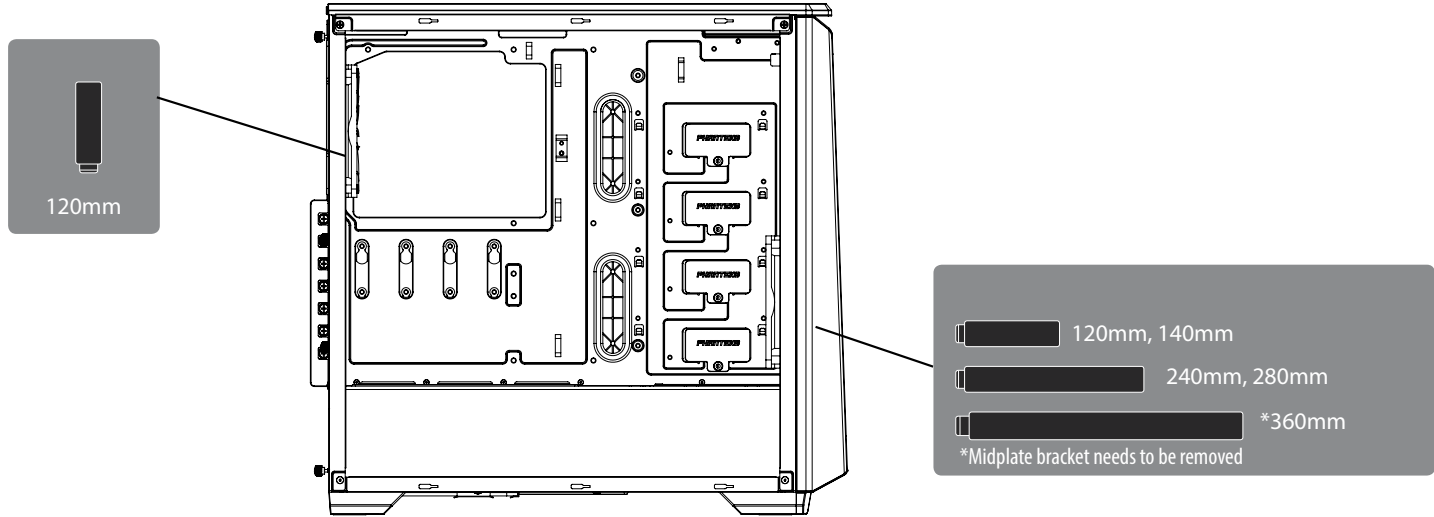

14. WATERCOOLING INSTALLATION

120 MM FORM FACTOR RADIATORS

Radiator Size	Front	Rear	Top
<i>Taille de radiateur</i> <i>Kühlkörpergröße</i> <i>Dimensioni del radiatore</i> <i>Tamanho do radiador</i> <i>Tamaño del radiador</i> <i>Radiator lengte</i>	<i>Avant</i> <i>Vorderseite</i> <i>Parte frontale</i> <i>Frente</i> <i>Frontal</i> <i>Voorkant</i>	<i>Arrière</i> <i>Rückseite</i> <i>Parte posteriore</i> <i>Traseira</i> <i>Posterior</i> <i>Achterkant</i>	<i>Dessus</i> <i>Oberseite</i> <i>Parte superiore</i> <i>Topo</i> <i>Superior</i> <i>Bovenkant</i>
120mm	✓	✓	
240mm	✓		
360mm	✓		

140 MM FORM FACTOR RADIATORS

Radiator Size	Front	Rear	Top
<i>Taille de radiateur</i> <i>Kühlkörpergröße</i> <i>Dimensioni del radiatore</i> <i>Tamanho do radiador</i> <i>Tamaño del radiador</i> <i>Radiator lengte</i>	<i>Avant</i> <i>Vorderseite</i> <i>Parte frontale</i> <i>Frente</i> <i>Frontal</i> <i>Voorkant</i>	<i>Arrière</i> <i>Rückseite</i> <i>Parte posteriore</i> <i>Traseira</i> <i>Posterior</i> <i>Achterkant</i>	<i>Dessus</i> <i>Oberseite</i> <i>Parte superiore</i> <i>Topo</i> <i>Superior</i> <i>Bovenkant</i>
140mm	✓		
280mm	✓		

***Caution: Supported Radiator size and thickness varies depending on your setup.**

*Avertissement : Les tailles de radiateur et les épaisseurs supportées varient en fonction de votre configuration.

*Achtung: Unterstützte Kühlkörpergröße und -dicke variieren je nach Aufbau.

*Attenzione: Le dimensioni e lo spessore supportati per il radiatore dipendono dalla configurazione.

*Atenção: O tamanho e espessura do Suporte do Radiador variam dependendo da configuração.

*Precaución: el grosor y el tamaño del radiador compatibles varían según la instalación que realice.

*Let op : Ondersteunde radiator grootte en dikte varieert afhankelijk van de opstelling.

15. OPTIONAL UPGRADES

3.5" HDD MODULAR BRACKET INSTALLATION (UP TO 4X EXTRA HDD'S)

REQUIREMENTS: PHANTEKS 3.5" HDD MODULAR BRACKET (*PH-HDDKT_02*)
(NOT INCLUDED)

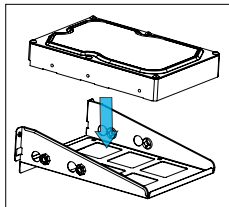

*Bracket not included

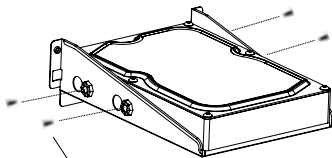

Requires 4x 6-32x5mm screws

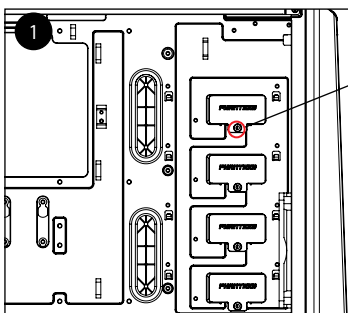

Front View

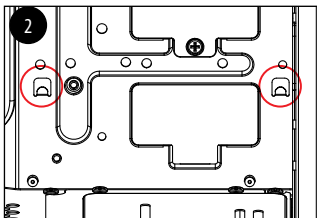
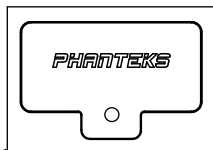

Front View

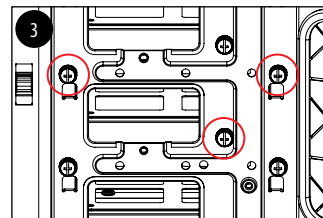
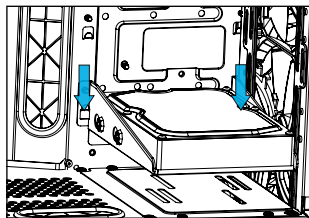

Back View

Step 1. Remove the HDD cover by removing the m3 Screw

Step 2: Align the HDD bracket to the slot and drop in.

Step 3: Screw in from the back with thumb screws to lock the bracket in place.

Passo 1: Retire a tampa do HDD retirando o parafuso m3

Passo 2: Alinhe o suporte do HDD ao slot e solte-o.

Passo 3: Parafuse da parte de trás com parafusos borboleta para travar o suporte no lugar.

Schritt 1: Entfernen Sie die Festplattenabdeckung durch Lösen der m3-Schraube.

Schritt 2: Richten Sie die Festplattenhalterung mit dem Steckplatz aus und stecken Sie sie hinein.

Schritt 3: Befestigen Sie die Halterung mit Rändelschrauben von der Rückseite kommend.

Fase 1. Rimuovere il coperchio dell'HDD svitando le viti m3

Fase 2: Allineare la staffa del disco rigido nell'alloggiamento e inserirlo.

Fase 3: Avvitare all'interno dal retro con viti ad alette per bloccare la staffa in posizione.

Passo 1: Retire a tampa do HDD retirando o parafuso m3

Passo 2: Alinhe o suporte do HDD ao slot e solte-o.

Passo 3: Parafuse da parte de trás com parafusos borboleta para travar o suporte no lugar.

Paso 1: Quitar la tapa de la unidad de disco duro retirando el tornillo M3.

Paso 2: Alinear el soporte de la unidad de disco duro con la ranura y colocar.

Paso 3: Atornille desde la parte posterior con los tornillos de apriete manual para bloquear el soporte en su lugar.

Stap 1: Verwijder de HDD deksel door 1x schroef te verwijderen (M3)

Stap 2: Breng de HDD beugel in positie en schuif vast.

Stap 3: Gebruik 3 handschroeven om de beugel te bevestigen.

15. OPTIONAL UPGRADES

PWM FAN HUB INSTALLATION

REQUIREMENTS:

PHANTEKS PWM FAN HUB (*PH-PWHUB*)
NOT INCLUDED



Step 1. Unscrew the side screw (A) to open top cover.

Step 2. Place the pwm board (without top cover) onto the mounting area of the Phanteks chassis.

Step 3. Screw in the 2 included screws

Step 4. Close the top cover and screw in the side screw (A).

Étape 1. Dévissez la vis latérale (A) pour ouvrir le couvercle supérieur.

Étape 2. Placez la carte MLI (sans couvercle supérieur) sur la zone de montage du châssis Phanteks.

Étape 3. Serrez les 2 vis incluses

Étape 4. Fermez le couvercle supérieur et serrez la vis latérale (A).

Schritt 1. Lösen Sie die seitliche Schraube (A) zum Öffnen der oberen Abdeckung.

Schritt 2. Platzieren Sie die PWM-Platine (ohne obere Abdeckung) im Montagebereich des Phanteks-Gehäuses.

Schritt 3. Drehen Sie die 2 mitgelieferten Schrauben fest

Schritt 4. Schließen Sie die obere Abdeckung und drehen Sie die seitliche Schraube (A) fest.

Fase 1. Svitare la vite laterale (A) per aprire il pannello superiore.

Fase 2. Posizionare la scheda pwm (senza il pannello superiore) sull'area di montaggio del telaio Phanteks.

Fase 3. Avvitare le 2 viti incluse

Fase 4. Chiudere il pannello superiore e avvitare la vite laterale (A).

Etapa 1. Solte o parafuso lateral (A) para abrir a tampa superior.

Etapa 2. Coloque a placa pwm (sem tampa superior) na área de montagem do chassi Phanteks.

Etapa 3. Aperte os 2 parafusos incluídos

Etapa 4. Feche a tampa superior e prenda a parafuso lateral (A).

Paso 1. Desatornille el tornillo lateral (A) para abrir la tapa superior.

Paso 2. Coloque la tarjeta pwm (sin tapa superior) en el área de montaje del chasis Phanteks.

Paso 3. Atornille de los dos tornillos incluidos.

Paso 4. Cierre la tapa superior y atornille el tornillo lateral (A).

Step 1. Maak de zijschroef los (A) om de behuizingkap te openen.

Step 2. Plaats de PWM board (zonder behuizingkap) op de installatie punt.

Step 3. Maak de PWM board vast met de bijgeleverde 2x schroeven.

Step 4. Plaats de behuizingkap weer terug en maak deze vast met de zij schroef (A).

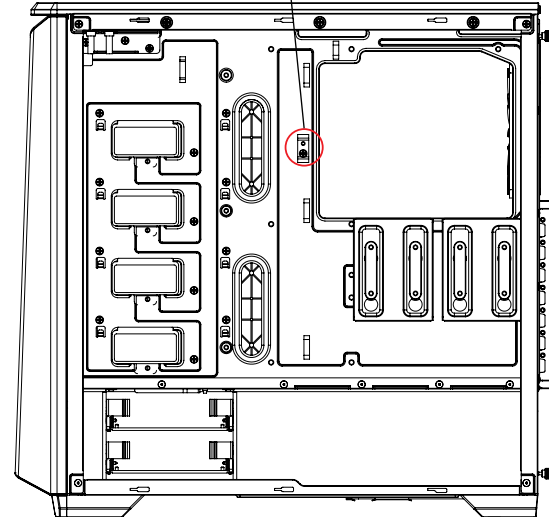
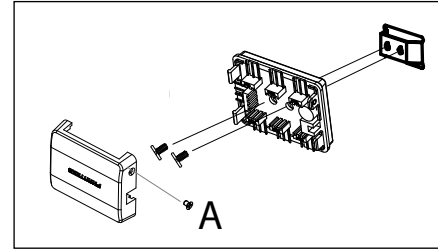

16. SERVICES AND SUPPORT

If you have any questions or concerns, please visit Phanteks' website for technical support. We consider customer support, satisfaction and feedback an essential element of our overall marketing effort. Please feel free to contact our support team. Thank you!

Contact Us at:
www.phanteks.com
www.phanteksusa.com
www.phanteks.cn

For Warranty Information, please visit Phanteks' website.

PHANTEKS
DESIGNED IN THE NETHERLANDS